

# Webasto - AIR CONDITIONING

## SELF-CONTAINED UNITS - WBCC SERIES OPERATION AND INSTALLATION MANUAL

FUNCTIONING PRINCIPLES

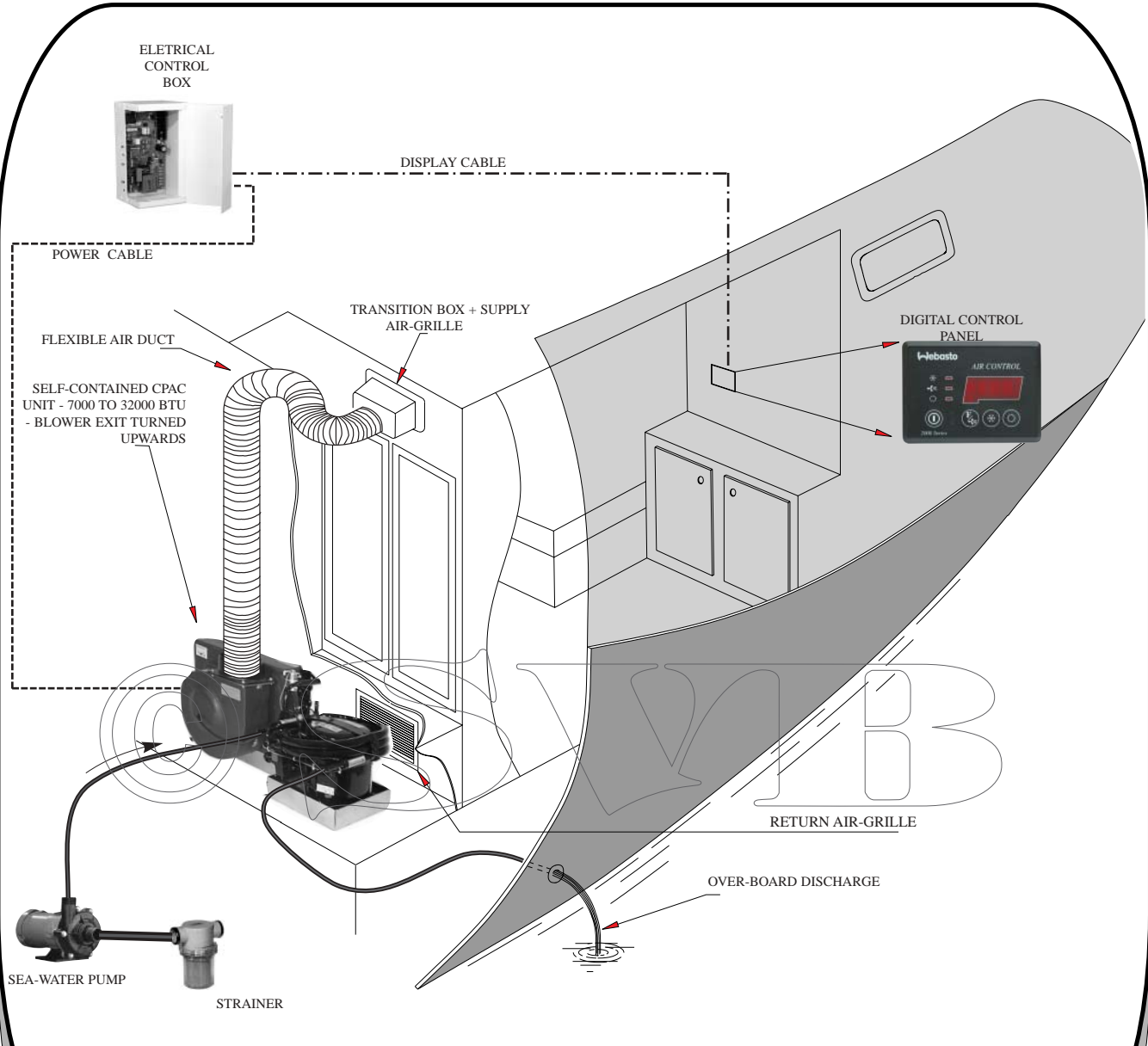

### NEW ELECTRONICS - 2000 SERIES

#### SELF CONTAINED UNITS



# SELF-CONTAINED AIR-CONDITIONING UNITS - WBCC SERIES

## OPERATION AND INSTALLATION MANUAL

### CONTENTS

	Page
1) General Information .....	3
2) Digital Control - Operation Guidelines .....	4
2.1 - Digital Display <AIR CONTROL> - Basic Commands .....	4
3) Secondary Commandes by F/Blower key .....	5
4) Visual Error Codes - Digital Display .....	5
5) Central Blower Control .....	5
6) Programmable Functions .....	7
6.1 - Digital Display <AIR CONTROL> - Programming access .....	7
7) Pratical Installation Guide - Components (Pumps, accessories, etc) .....	8
8) Routine Checks .....	9
8A) Trouble Shooting .....	9
9) Air-Ducting and Ventilation .....	10
10) Wirings Schematics .....	11
10.1 - Wiring diagram - WBCC 5 to 16 - single phase - Rotary compressors .....	11
10.2 - Wiring diagram - WBCC 24 and 30 - single phase - Rotary/Scroll compr. ....	12
10.3 - Wiring diagram - WBCC 5 to 16 - single phase - Piston Compr. (<2000) ....	13
10.3 - Wiring diagram - Wiring Running Capacitor - Blowers .....	13

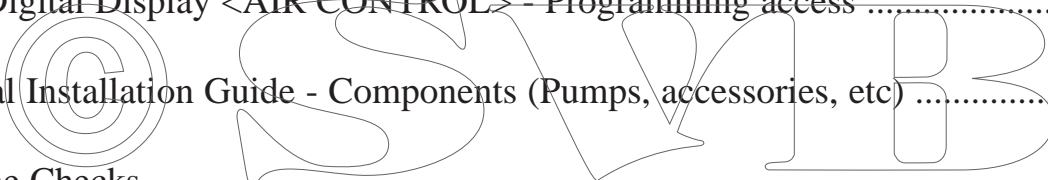

## HOW DOES IT WORK ?

All air-conditioning units based on hermetic compressors function on the same principle : a compressor compresses the refrigerant gas which is then condensed to liquid when passing through a sea-water cooled condenser. Subsequently the liquid

refrigerant is injected through a small nozzle and evaporates. This evaporation process produces the refrigeration effect. The evaporation takes place in a tubular finned coil (also called : evaporator coil). A blower forces the air through the evap-

orator coil.

While passing through the evaporator the temperature of the air is lowered by approximately 15 °C.

So far for the general principles.

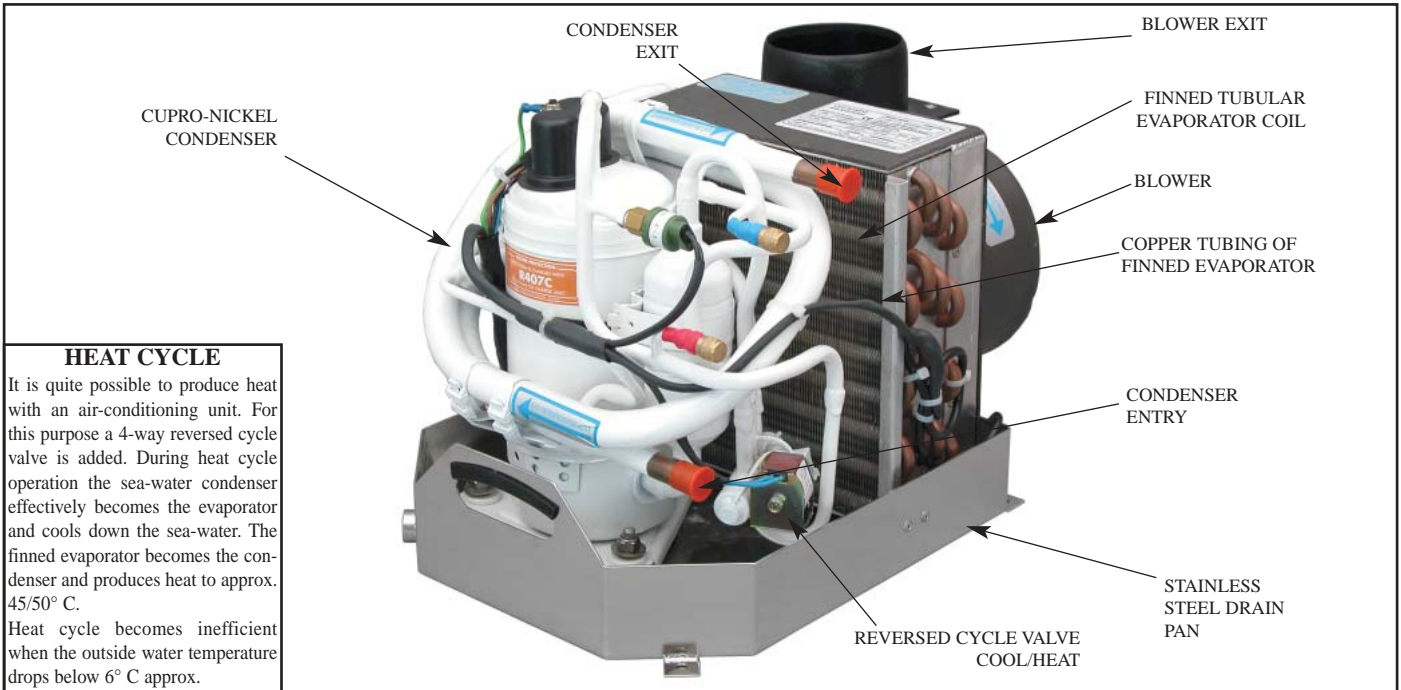

### HEAT CYCLE

It is quite possible to produce heat with an air-conditioning unit. For this purpose a 4-way reversed cycle valve is added. During heat cycle operation the sea-water condenser effectively becomes the evaporator and cools down the sea-water. The finned evaporator becomes the condenser and produces heat to approx. 45/50° C.

Heat cycle becomes inefficient when the outside water temperature drops below 6° C approx.

### 1. GENERAL INFORMATION

All WEBASTO air conditioning units are controlled by a Digital Display <AIR CONTROL> which gives access to all functions necessary for the normal operation of the unit and attached accessories (blowers, pumps, etc).

All WEBASTO air conditioning units are sea-water cooled by means of an AC sea-water pump.

In order to start the system you only need to press the <POWER> key on the digital display.

From there on the electronic control unit takes care of the progressive starting up of the air conditioning unit as well as its normal functioning.

The digital display will show the present air temperature of the cabin in which the digital display is situated or where the main temperature sensor is located (in case the optional secondary temperature sensor is used).

After a delay of approx. 20 seconds the display will indicate the cycle in which operation will start i.e. <COOL> or <HEAT>. The choice will depend upon

the set-point temperature and the air-temperature as measured by the display panel.

After a further delay of approx. 50 seconds the compressor(s) will start up and the normal operation cycle will begin.

### 2000 SERIES DIGITAL DISPLAY

As from September 2000 all WEBASTO air conditioning units are controlled by a Digital Display <AIR CONTROL> 2000 SERIES which gives access to all functions necessary for the normal operation of the unit and attached accessories (blowers, pumps, etc). 2000 Series Electronic Controls are easily

## STANDARD ELECTRICAL ACCESSORIES

### MINIMUM STANDARD CONTROL ELEMENTS DELIVERED FOR ALL CPAC SELF-CONTAINED UNITS

Summary : 1 Alu control box + 1 display cable + 1 digital control panel (External air-sensor is optional)

#### ELECTRICAL CONTROL BOX

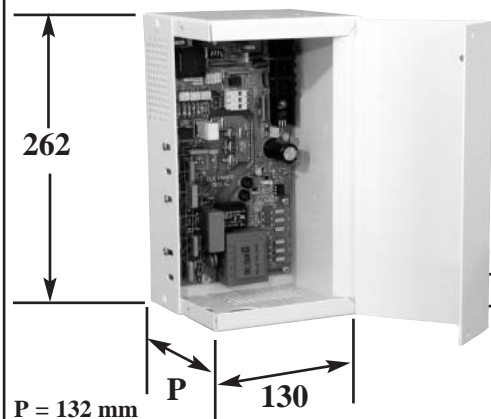

#### DIGITAL DISPLAY PANEL



DISPLAY CABLE

OPTIONAL EXTERNAL AIR SENSOR

## 2 - DIGITAL WBCC/BLOWER CONTROL - GENERAL PRINCIPLES

**BASIC COMMANDS :**

- 1 - Press to turn on - press again to turn off.
- 2 - Press to read set-point temperature - hold to raise set-point temperature.
- 3 - Press to read set-point temperature - hold to lower set-point temperature.
- 4 - Led indicating system working in cool mode
- 5 - Led indicating manual blower speed control is active
- 6 - Led indicating system working in heat mode
- 7 - Function/Blower Key - immediate access to :
  - blower speed control .....
  - evaporator temperature read-out .....
  - manual cycle choice (cool, heat, auto-reverse) ....
  - AC voltage read-out .....
  - selective on/off compressors 1 to 4 .....
  - starting priority compressors 1 to 4 .....
  - automatic dehumidifying cycle during absence
  - display time secondary functions accessible by F/Blower key
- 8 - Push Both Keys Simultaneously after Display Extinction

8 - Access to hidden programming functions - see page 7.

*Default Values	
*b	A
H	13.2
*F	3
U	230
1C	01 etc
P	123 etc
*d	0
*t	1

**DRAWING 2.1 - BASIC AND SECONDARY COMMANDS**

recognized by the inscription <2000 Series> at the bottom left hand corner of each digital display.

All WEBASTO air conditioning units are sea-water cooled by means of an AC sea-water pump.

In order to start the system you only need to press the <POWER> key on the digital display.

From there on the electronic control unit takes care of the progressive starting up of the air conditioning components as well as its normal functioning.

The digital display will show the present room temperature of the cabin in which the digital display is situated or where the main temperature sensor is located (in case the optional secondary temperature sensor is used).

The WEBASTO <AIR CONTROL> digital display allows gives access to information and controls at three distinct levels :

### Immediate Access - Level 1 :

- 1) Room temperature read-out in the main 4 LED display window
- 2) 3 small LED's to the left indicating the operating cycle presently active :
  - Cool cycle only operation.
  - Automatic cycle switching governed by end-user entered set-point temperature.

- Heat cycle only operation.

3) 2 set-point keys give immediate access to the thermostatic set-points for blower control ("Sun" and "Snow" key). These keys are also used to alter programming values - see here-after chapter 6.

### Secondary commands and info - Level 2 :

4) The F/Blower key gives immediate access to a number of secondary commands which need to be accessed frequently for day to day operation.

First access is to blower speed control, then evaporator temperature read-out, etc.

See hereafter drawing 2.1 for complete list.

### Programming Commands - Level 3 :

A number of programming commands that do not need to be accessed for day to day operation are hidden and require a special procedure to enable access and modification. An access code can be enforced to avoid accidental modification of programming values.

See Chapter 6 - Page 7.

### Start-up delay :

After pushing the on/off key the LED's will display <ON> while initializing the system. Push again to stop operation - the display

will briefly show <off> before extinction.

The adequate LED to the left (heat, cool, etc) will come on after approx. 20 seconds and compressor operation will start after approx. 60 seconds.

The sea-water circulation pump will come on approx. 9 seconds before compressor start.

### Modification of set-point temperature :

The set-point temperature i.e. the temperature desired by the operator for blower operation directly connected to the TCC controller card, can be modified as following :

Press and hold one of the set-point selector keys and wait until the new desired set-point temperature is obtained. Release the set-point key.

The display will return to normal room temperature read-out after approx. 5 seconds.

See drawing 2.1 - page 4 for visual operation guide.

Non-volatile memory keeps last settings.

### Special New Features - 2000 Series :

**A) Automatic blank/sleep mode** - programmable time delay. Factory default : 15 minutes. While in blank/sleep mode the cycle LED flashes discretely every 20 seconds. To go back to normal operation push any key.

**B) Calibrate all blower speed settings** in real time mode.

It is now possible to calibrate all speed settings (1 to 5) before actually putting the system into service.

To do so enter programming mode with set-point at 15° C.; proceed to following line i.e. code <6> = speed 5 (max).

The blower will start to function as soon as you access code <6>.

Alter value to the right of code <6> and blower speed will immediately change in real time. When satisfied go to following line <7> = speed 4 and do the same.

Proceed until lowest speed N° 1 and go back again to speed N° 5 if not satisfied.

When all speeds are programmed according to need, validate by pushing on/off key (<memo> will be displayed briefly). See also page 8 - programming access.

**Attention : Never program speeds so low that the blower is in danger of stopping or will not re-start at that setting. This will inevitably entail motor-windings burn-out and will not be covered by WEBASTO warranty.**

**C) Automatique De-Icing Control :**

During intermediate seasons (spring, autumn) when moderate temperature conditions prevail, there is a definite risk of icing the evaporator coil in cool mode and pressure safety cut-outs in heat mode.

To allow maximum blower speed variation and still function within a normal operating window, the TCC card is equipped with a second temperature sensor which reads the exact evaporator coil temperature.

Whenever coil temperature approaches the danger zone, blower speed is increased to half speed; if that is not sufficient the micro-processor will stop compressor operation for pre-determined intervals and will resume normal operation when coil temperature has moved back to within normal operating values.

This feature is completely transparent to the end-user without an error code display; in short this feature belongs to the normal operating procedures in the same way as the temperature set-points.

**D) Infra-Red Remote Control :**

Infra-red remote control can be obtained as an option. This remote control is based on the standard protocols also used by TV and other appliances. Although the WEBASTO controls have been chosen so as to avoid interference with most TV models, the end-user should be aware that in certain cases interference may occur with TV sets or other appliances.

In general it is therefore advisable to avoid locating a WEBASTO Air Control panel next to other appliances using infra-red control units whenever it is planned to use infra-red control mode.

**D) ACCESS CODE :**

The end-user can deny access to all program settings by introducing an access code (see page 8 - code <b>). Blower speed and set-points always remain accessible.

Once an access code is validated, the digital panel will show <Code> if the end-user tries to access other functions then blower speed or set-point. To gain full access push the sun key to reach the code number as programmed and push the <F> key again to gain access to full program-settings.

**3. SECONDARY COMMANDS :**

The F/Blower key gives immediate access to commands and display necessary for day to day operation. When pushing the F key you will see to the left a code which indicates the type of display or command and to the right the present value.

In order of appearance here-after an explanation of these commands/displays :

- a) Blower speed control : < b A> (0,1,2,3,4,5)

This command preceded by the letter b (blower) allows the following settings : A = automatic blower speed adjusted to temperature differential.

1 to 5 = Manual Speed Control  
Speed control is in real time mode i.e. changes are effected immediately without any validation procedure.

**Attention : All following functions need validation before a new value is accepted. Validation is obtained by pushing the F key again and by going to the next function line. Then final validation will occur**

**automatically when the display goes back to room temperature read-out or final validation can be forced by pushing the on/off key briefly while still in F mode.**

**Validation is witnessed by the brief display of the message <memo>.**

- b) Read out of evaporator coil temperature : <E10.2> (10.2 ° C) - example.

- c) Cycle mode choice : <F 3> (1 to 4)  
The following cycle modes can be chosen manually :

- 1 = cool cycle only
- 2 = heat cycle only
- 3 = automatic cycle switching with reversible compressor
- 4 = automatic cycle switching without reversible compressor

- d) AC Voltage read-out : < U232> (232 Volts) - example

- e) Manual on/off Compressor 1 : <1C01>  
<1C01> = Compressor 1 on  
<1C00> = Compressor 1 off

- f) Manual on/off Compressor 2 : <2C01>  
<2C01> = on  
<2C00> = off

Idem for compressors 3 and 4 - <3C01> and <4C01>.

- g) Starting Priority Compressors 1 to 4 :  
<P123> = 1,2,3,4 ; <P341>=3,4,1,2  
<P A> = automatic priority rotation; when in this priority mode, the starting order will be changed every next restart after thermostatic cut-out.

- h) Starting delay between compressors : <L 9> (9 seconds) - programmable between 1 and 9 seconds.

- i) Automatic dehumidification while absent.  
factory default setting : <d 0>  
0 = non active  
1 = 1 cycle per 24H  
2 = 2 cycles per 24H etc

- k) display time of secondary functions (F/ Blower key) by periods of 20 seconds.  
<t 1> (factory default setting) = display time 20 seconds.

**4. VISUAL ERROR CODES - DIGITAL DISPLAY**

The following malfunctions will be displayed directly on the digital display by a

code and will be followed by a system halt. Whenever any of these codes appear the system is stopped for approx. 60 seconds and then a re-start is attempted.

If for more than 30 minutes the same malfunction occurs, the system will be stopped completely and the error-code will become steady.

No more re-starts will be attempted and the user will have to re-set the system by pushing the ON/OFF switch or by temporarily cutting out the AC supply to the system.

**List of error-codes and nature of malfunction :**

**Code <AAA> :**  
Persistent low voltage (voltage below 195V) for more than 5 seconds - (see also hereafter - Trouble-Shooting - Page 9).

**Code A01 to A08 \*) :**

Pressure safety cut-out of compressors 1 to 4. The HP and BP (if present) safety controls are directly controlled by the micro-processor inclusive the time-delays for re-start, etc.

**\*) Standard TCC controller cards** have only 1 outlet for 1 single compressor. However the embedded micro-processor program can operate up to 4 CPAC units from 1 single controller card. This special controller card can be obtained on special request but is not standard delivery.

Error codes displayed and probable nature of anomaly.

<A01> : BP (low pressure) cut out - compressor 1 - probable causes :  
- insufficient refrigerant charging level  
- abnormal sea-water temperature conditions in heat cycle (sea-water temperatures under 6° C. approx.)  
- first start-up in heat cycle with very low chilled water circuit temperatures (below 8° C approx.).

**ATTENTION :** models CPAC5 to 16 do not have a low pressure safety switch (BP); therefore if you see a A01 warning on such model, it can only be an electrical connection problem on the grey 3 pole HP/BP connector on the TCC controller card. Check that the connector is properly seated and that the BP strap is properly tightened.

<A02> : HP (high pressure) cut out - compressor 1 - probable causes :  
- insufficient or non-existent sea-

water cooling - check sea-water pump.  
- too much refrigerant in system - call specialist  
- abnormal sea water temperature conditions in heat cycle (sea-water temperatures above 17° C approx.)

<A03> : BP cut out - compressor 2 - for probable causes see <A01>

<A04> : HP cut out - compressor 2 - see <A02>

<A05> to <A08> - same as above for compressors 3 and 4 (if present).

If any of these error codes appear too frequently and no appropriate action can be taken with the available means on board, it is necessary to call a specialist.

Do not insist with manual re-starts in such case as this may cause major damage to the principal components (compressors, pumps, etc).

<A09> - absent or defective external or internal (Display Face) air sensor

<A10> - absent or defective evaporator temperature coil sensor.

<CA11> - all compressor(s) have been deactivated by soft - <F> procedure : <1C00>, <2C00>, etc  
To re-activate, reprogram as follows : <1C01>, etc

<EA11> - compressor stopped by de-icing control - automatic restart - this code does not entail a complete system halt and will only be visible when in reading out the evaporator temperature (F key - line E).

**5. CENTRAL BLOWER CONTROL**

The central <AIR CONTROL> digital display also directly controls the blower(s) of the evaporator(s).

For all CPAC systems, there are two modes of blower control and operation :

- thermostatic interruption of blower operation as soon as the desired set-point temperature has been reached.
- un-interrupted blower operation regardless of thermostatic compressor control.

The choice between these two functioning modes can be programmed directly by the end user - see here-after Chapter 6 - programming procedures.

The digital control is initially programmed by the manufacturer in second - i.e. un-interrupted blower operation.

Blower control can be manual with 5 different speed levels or automatic; in this case blower speed will be governed by the temperature differential with the set-point temperature.

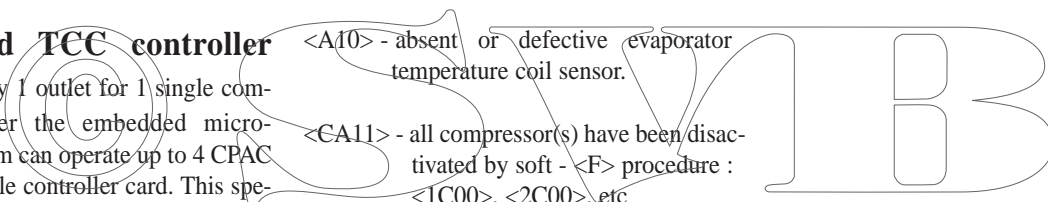

## 6 - DIGITAL DISPLAY <AIR CONTROL> - PROGRAMMING ACCESS



### PROGRAMMING MODE :

To enter programming mode : raise or lower set-point to 29 or 15° C.  
Turn off system by pressing <Power> key - 14.

Press simultaneously keys <11>. The display will show to the left <15>, the number code of the current programming line and to the right <16> the present value.

To validate and memorize modified parameters press the <F> key (12) and proceed to the following programming line.

To gain access to the hidden programming functions proceed as following :

Raise set-point to max. value i.e. 29° C (or alternatively to lowest value i.e. 15° C) - push Off key to extinguish digital display.

Press <snow> and <sun> key simultaneously for approx. 3 seconds until you see to the left of the display window a single number code indicating the programming line presently valid and to the right the programming value.

To go to the next programming line, push the <F> key.

If you modify the programming value of any line, you need to validate this new value by pushing the <F> key again to move to the next line. This step will validate and memorize the changes made.

### 1° Functions accessible by raising the set-point to 29° C. :

**Code <0>** - factory setting : -1° Celsius - lower set-point temperature of the evaporator coil temperature in cool cycle. Gives the compressor cut-out point when the “de-icing” procedure is activated.  
Adjustment range : between -5° C. and +10° C.

**Code <1>** - factory setting : +7° Celsius - higher set-point temperature of de-icing procedure. This value gives the re-start point of the compressor(s) after an interruption when in de-icing mode.  
Set-point temperature adjustable between 0°C. and +12° C.

**Code <2>** - factory setting : 40° C. higher set-point temperature of the “de-icing” procedure in relation to the evap. coil temperature when in heat cycle (to avoid HP cut-outs). Gives the cut-out point of the compressor(s) when functioning in heat cycle.

Set-point temperature adjustable between 35° and 50° C.

**Code <3>** -factory setting : 35° C. - lower set-point temperature of coil temperature cut-in when in heat cycle. Gives the cut-in point of the compressor(s) after an interruption (“de-icing” procedure) when functioning in heat cycle.

Set-point temperature adjustable between 30° and 50° C.

**Code <4>** - pre-programmed value : 0 - calibration of temperature display of the evaporator coil temperature read-out - correction possible between -9° to +9° Celsius.

**Code <5>** - factory setting : 15 - time delay in minutes before the digital display goes into blank/sleep mode. Cycle LED flashes discretely to indicate system is operational.

**Code <6>** - factory setting : 1 - time delay first start up in seconds. To stage starting of several CPAC units when switching on AC supply after an interruption.

**Code <7>** - factory setting : 0 - calibration of room temperature read-out. Possible between +9 and -9° C.

**Code <8>** - pre-programmed value : 0. Factory calibration of AC voltage 50 Hz as displayed on the digital panel when accessing the secondary commands - F key.

Correction between -20 and +20 Volt.

**Code <9>** - pre-programmed value : 1 - Time delay before re-start in minutes after a compressor stop when in “de-icing” procedure. (both for cool and heat cycle).

**Code <A>** - pre-programmed value : N/A. Factory calibration of AC voltage 60 Hz as displayed on the digital panel when access-

ing the secondary commands by the F key.

Correction between -30 and +20 Volt

**Code <b>** - Program version

### Re-initializing of factory default settings :

It is possible to force the program to re-initialize all program values to factory default settings by the following procedure :

When reading the <b> line as above (through the 29° set-point), push the <sun> key; continue to push; the program version will start to flash. Keep the <sun> key pushed down until the display shows <init>.

Leave programming mode by pushing On/Off key - you are now back to the factory default settings.

**Attention :** this procedure should never be attempted for any program version below a value of 1.00 - i.e. for <b0.12> never attempt to reinitialize the default settings : your controller card will lock itself and cannot be unlocked.

On the contrary - example : program version <b1.02> or <b2.03> : OK to re-initialize.

### 2° Functions accessible when lowering the set-point temperature to 15° C :

**Code <0>** - pre-programmed value : 195 - low voltage cut-out value AC.  
Time delay is 5 seconds approx. i.e. the low voltage situation will have to persist during more than 5 seconds before cut-out occurs.

After cut-out the electronic controller resets and will start a new cycle. So a renewed attempt to start the compressor will occur after approx. 90 seconds.

During low-voltage cut-out the display panel will show the 3 letters <AAA>.

Programming of a cut-out level below 195 V is done at the entire risk of the operator. It should be noted that almost all compressor manufacturers decline all responsibility for defects resulting from operating the compressors below 195V AC.

**Code <1>** - factory setting : 0 - infra-red remote control :  
 0 = infra-red remote control disabled (in this mode no interference is possible with other infra-red commands)  
 1 = infra-red remote control active

**Code <2>** : Blower type : Centrifugal or Cross-Flow. Factory default : 1  
 0 = centrifugal blowers only  
 1 = centrifugal + cross-flow

**Code <3>** - pre-programmed value : 1 - basic choice of blower control :  
 0 - thermostatic control of blower operation i.e. blower operation will be interrupted thermostatically when reaching the appropriate set-point.  
 1 - un-interrupted blower operation regardless of the thermostatic control.

**Code <4>** - factory setting : 1 - Choice between integrated air sensor and external air sensor :  
 1 - air sensor integrated in digital display  
 0 - external air sensor

**Code <5>** - Celsius or Fahrenheit display - factory setting : 1  
 0 = Celsius read-out  
 1 = Fahrenheit read-out

**Code <6>** : modification speed N° 5 (max)  
**Code <7>** : idem speed N° 4

**Code <8>** : idem speed N° 3  
**Code <9>** : idem speed N° 2  
**Code <A>** : idem speed N° 1

**Code <b>** - factory setting : 0 - access code for programming mode.  
 0 = no access code required  
 1 to 99 = access code/number activated

\*) Factory access code : in case the system is blocked and the access code cannot be found, you can access the programming line by using the factory code number : 64

**Code <c>** - factory setting : 1 - duration in minutes of heat cycle dehumidifying cycle.

**Code <d>** - factory setting : 1 - duration in minutes of cool cycle dehumidifying cycle.

**DIPSWITCHES :**

The TCC controller card has a dipswitch arrangement which should be set and maintained according to the following settings :

1) TCC controller for single compressor , without the secondary card for compressors 3 and 4 :

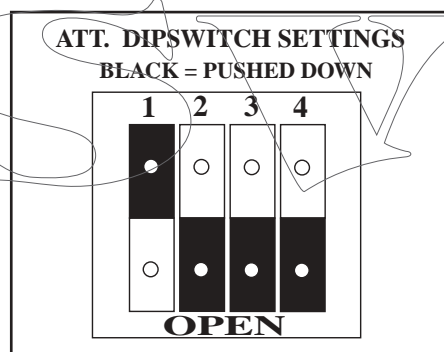

**Attention :** if dipswitches are not set according to the above configurations i.e.

according to the number of compressors effectively on line, the TCC controller card may behave in unpredictable manner :

- the initialisation <init> can not be completed - card remains locked on start-up.

- HP/BP alarms for non-existing compressors.

**7. PRACTICAL INSTALLATION GUIDE**

**1) Sea-water cooling :**

Install the pump/strainer assembly in such a manner that a natural gentle upwards slope exists from the sea-cock to the pump itself. See also drawing hereabove ref. 6.1.

It is strongly recommended to install an air-bleeder system both in the suction line as well as immediately after the discharge outlet of the pump. The advice is especially valid for pumps WEBAS-TO250/350/1000. The WEBAS-TO1500/2000 and Calpeda pumps 0.5HP to 1 HP generally will not require a bleeder system to ensure proper operation.

For ALL boats it is strongly recommended to install a water-scoop at the entry of the sea-cock and directed towards the bow of the boat so that at speed positive pressure builds up in the supply line to the sea-water pump.

**2) Sea-water cooling exits :**

Provide for a separate sea-water exit for each air-conditioning unit installed even if only one pump provides cooling for all units.

**7.1 - INSTALLATION AND POSITIONING OF SEA-WATER PUMP AND ACCESSORIES**

TO OVER-BOARD OUTLET APPROX. 10 CMS ABOVE WATER-LINE

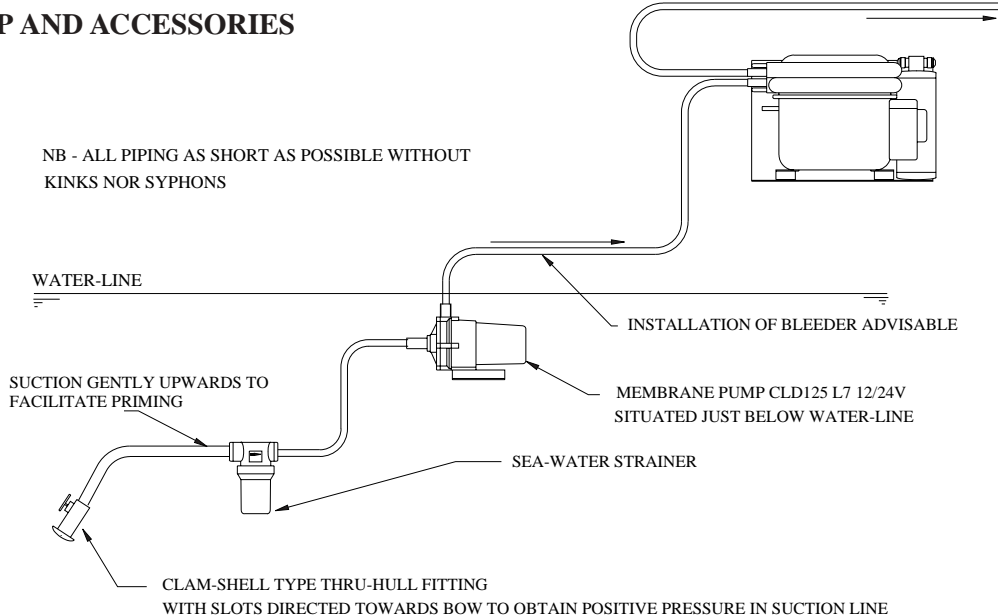

Introduce shut-off valves for each unit if 1 pump provides cooling for more than 1 air-conditioning unit.

This will allow easy priming of the circuit and also calibration of the sea-water flow for each air-conditioning unit in case of imbalance in the water tubing lengths.

**3) Evaporator coils :**

The finned coils of the evaporators and/or air-handlers are fragile. When during installation the fins of these coils are damaged, take care to re-align the fins in order not to impair proper air-flow.

**4) Air-ducts :**

Flexible air-ducts need to be of good quality with sufficiently strong steel or plastic re-reinforcement. Do not restrict air-flow by bending the air-ducts too tightly or by accidental local deformation.

Do not install air-ducts of excessive lengths (+ 2.5 ml); the pressure loss and consequent reduction of air-flow will seriously diminish the efficiency of the installation.

**8. ROUTINE CHECKS**

When starting up an air conditioning unit it is advisable to carry out a certain number of routine checks to ensure proper functioning of the unit.

- always check (especially after a long absence) the functioning of the sea water cooling system. Immediately stop the system if no sea-water comes out of the pump exit after compressor starts up.

- periodically check the air filter in the return air grilles. Clean if necessary.

- check condensation drain from the evaporator drain pan.

- take care not to damage the air-ducts. A damaged air-duct may stop air flow through the evaporator, freeze up the evaporator and subsequently damage the compressor.

- when preparing for winter lay-up take care to rinse all sea-water circuits with a fresh-water/glycol solution (25% or more depending on local winter conditions).

**8A. TROUBLE SHOOTING**

1) No sign of live : check main electrical supply, fuses, etc.

2) The digital display shows 3 lettres <AAA>. This means a persistent state of low voltage (less than 195 V AC). The system will re-start as soon as the voltage level climbs above cut-out level and the system will then re-start after a time-delay of 1 minute approx.

3) The compressor will start but no sea-water circulation can be observed :

- check sea-cock to sea-water pump.
- check sea-water strainer
- check if pump turns
- if the pump does not turn with the compressor working, check power-supply from the main control unit box to the pump.

4) Compressor and pump work but no correct operation in either cool or heat cycle :

- check proper air ventilation - blowers. If air flow completely stops with the compressor working, the evaporator coils may freeze up completely, obstructing all air circulation.
- during the heat cycle with too slow a sea-water circulation you may actually freeze up the sea-water in the cupro-nickel condenser and completely block the system.
- check voltage level. Do not operate a system with a persistent voltage level below 195 V AC.
- check freon charge if operation is still not satisfactory, after having checked all the above points.

5) The compressor works but is subject to intermittent stops without having attained the desired set-point temperature.

- the HP and BP (if present) pressure safety switches stop the compressor because of abnormal working pressures either on the high or on the low side. Check proper functioning of the cooling circuit. Check ventilator/blower system for obstructions.
- incorrect freon charge (over-charge or insufficient charge level).

See also here-above : Error codes/interrupted system operation.

6) The heat cycle takes very long to get started.

- normal if the sea-water temperature is very low. If sea-water temperature drops below approx. 8° C. the heat cycle becomes much less effective and takes long to get properly started.

\* \* \*

## 9 - AIR DUCTING - VENTILATION

### 1) MINIMUM AIR-GRILLE SECTIONS

In order to obtain an acceptable noise level at max. blower speed certain requirements as regards grille and ducts sections should be observed.

Also the size of the transition boxe behind the supply air-grille is important. See table here-under to choose correct grille sections according to BTU rating.

### 2) DUCT TYPE

Flexible air-ducts should be of high quality with sufficiently strong steel spiral re-inforcement to avoid accidental crushing.

Spiral type ducts should be extended to their

maximum possible length to obtain max. interior smoothness.

For very long duct sections preference should be given to rigid ducts (in PVC for example) which offer a far greater smoothness than flexible spiral type ducting and therefore will greatly reduce internal friction.

For very short lengths non-insulated ducts may possibly be used. Over greater lengths it is advisable to use insulated type ducts to avoid condensation on the outside of the air-ducts.

AIR/HANDLER-CPAC MODEL	SUPPLY AIR GRILLE		RETURN AIR GRILLE		DUCT DIAM.	
	MODEL/ SECTION	cm <sup>2</sup>	MODEL/SECTION	cm <sup>2</sup>	<1.8 M DUCT LEN.	>1.8 M DUCT LEN.
4000/4500 BTU	1 x 8x4"	150 cm <sup>2</sup>	1 x 12x5"	325 cm <sup>2</sup>	80 mm	100 mm
6000 BTU	1 x 10x4"	190 cm <sup>2</sup>	1 x 11x8"	490 cm <sup>2</sup>	100 mm	125 mm
9000 BTU	1 x 12x4"	235 cm <sup>2</sup>	1 x 11x8"	490 cm <sup>2</sup>	100 mm	125 mm
12000 BTU	1 x 10x5"	250 cm <sup>2</sup>	1 x 14x7"	550 cm <sup>2</sup> or	125 mm	150 mm
16000 BTU or	1 x 12x6"	390 cm <sup>2</sup>	1 x 14x10"	800 cm <sup>2</sup>	125 mm	150 mm
16000 BTU	2 x 10x4"	380 cm <sup>2</sup>			125 mm	150 mm
24000 BTU	2 x 10x5"	500 cm <sup>2</sup>	1 x 14x12"	1000 cm <sup>2</sup>	2 x 125 mm	2 x 150 mm
32000 BTU	2 x 12x5"	650 cm <sup>2</sup>	2 x 14x10"	1600 cm <sup>2</sup>	2 x 125 mm	2 x 150 mm

NB : For duct lengths over 1.80 ml, it may be possible to use the nominal duct diameter (for example 100 mm - 6000 BTU model), if instead of spiral type flexible ducts, rigid perfectly smooth interior ducts are used.

### 3) BLOWER OUTLETS

90° turns with flexible ducts directly from blower outlets should be avoided at all costs as they introduce severe restrictions in the air-flow.

All WEBASTO blowers (except on 24000 BTU models) can be rotated through 45° steps so as to obtain a straight-line outlet from the blower. This facility should be used whenever possible.

See also drawing to the right.

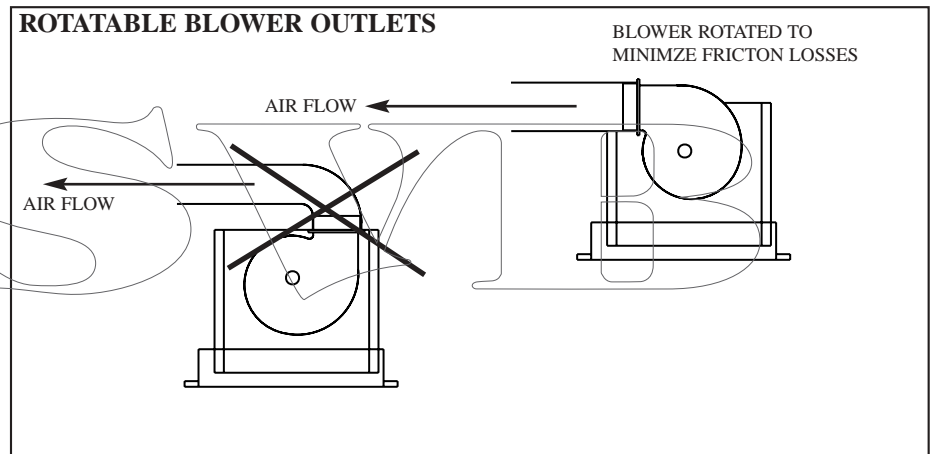

### 4) TRANSITION BOXES

Transition boxes behind supply air-grilles essentially serve the following purpose :

Serve as an expansion volume for the air-flow to be reduced in velocity and therefore reduce air noise when crossing the outlet louvres.

It follows therefore that the depth of the transition box is an important factor to allow dispersion of the air-flow

The table to the right gives the necessary information as to the minimum dimensions advisable for such transition boxes.

#### TRANSITION BOX INFORMATION

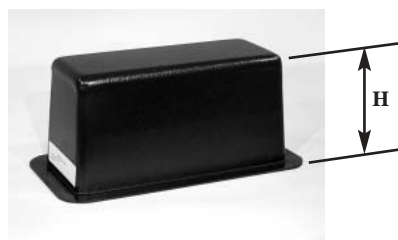

DUCT DIAM.	MINIMUM VALUE OF "H"
80 mm	100 mm
100 mm	120 mm
125 mm	140 mm
150 mm	165 mm

#### Deflection curve for longitudinal entry transition boxes

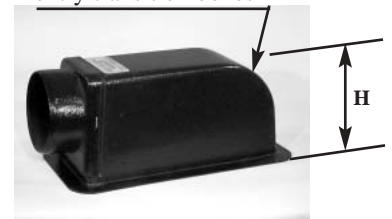

### 5) RETURN GRILLE OFFSET

It is best to avoid placing a return air grille directly opposite the finned coil surface of an air-handler. This will inevitably allow propagation of direct blower-motor noise through the grille.

Always try to offset the grille so as to chi-

can the return air to the coil inlet.

This will lower direct noise propagation in a significant manner.

# 10 - WIRING DIAGRAMS

## 10.1 - Wiring diagram WBCC 5000 TO 16000 BTU (Rotary Comp.) - single phase

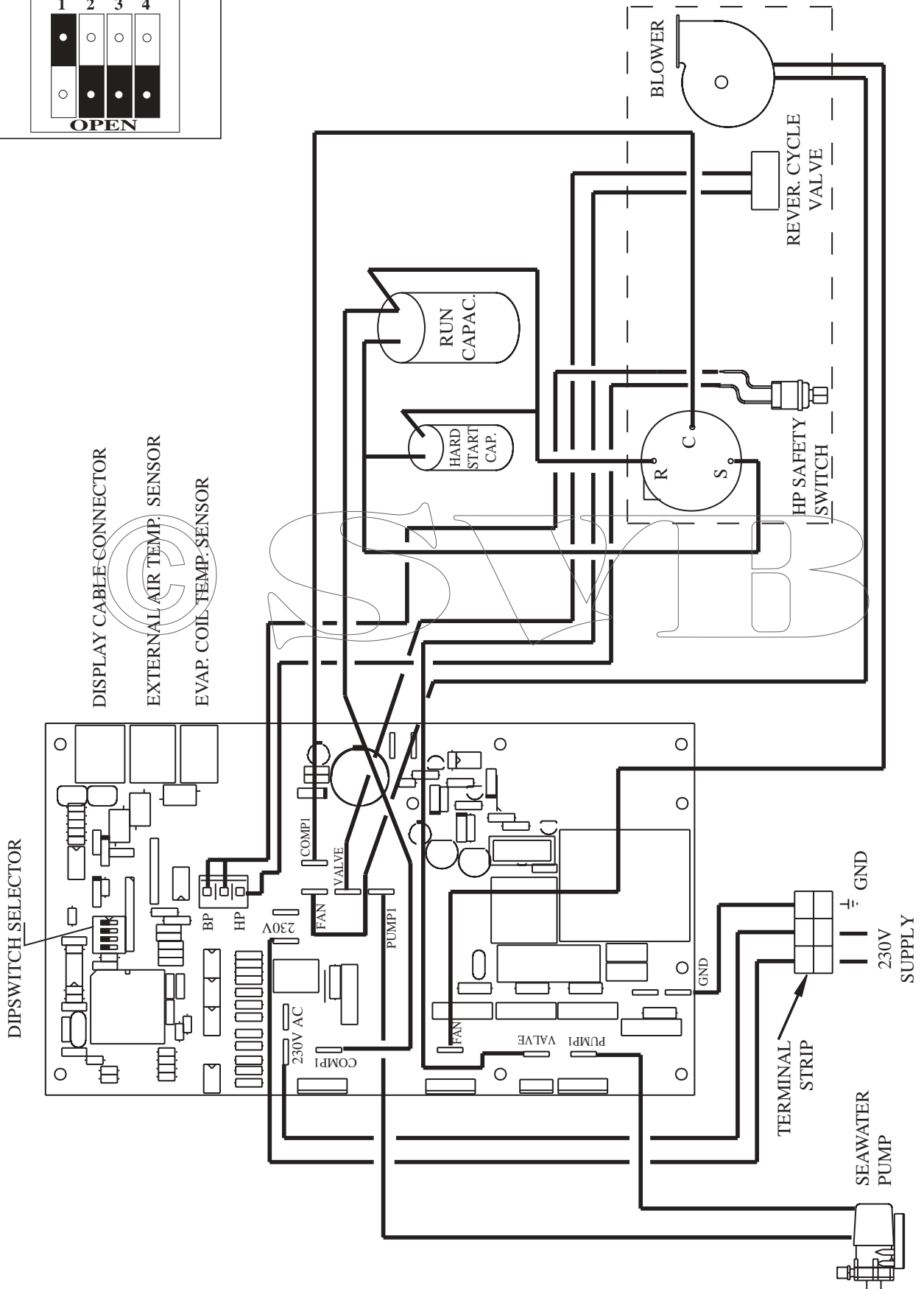
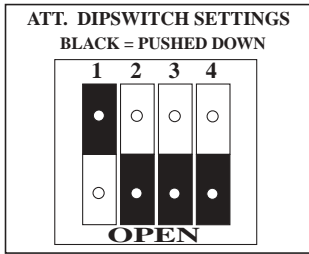

## 10.2 - ELECTRICAL WIRING - WBCC 24 TO 30 - SINGLE-PHASE

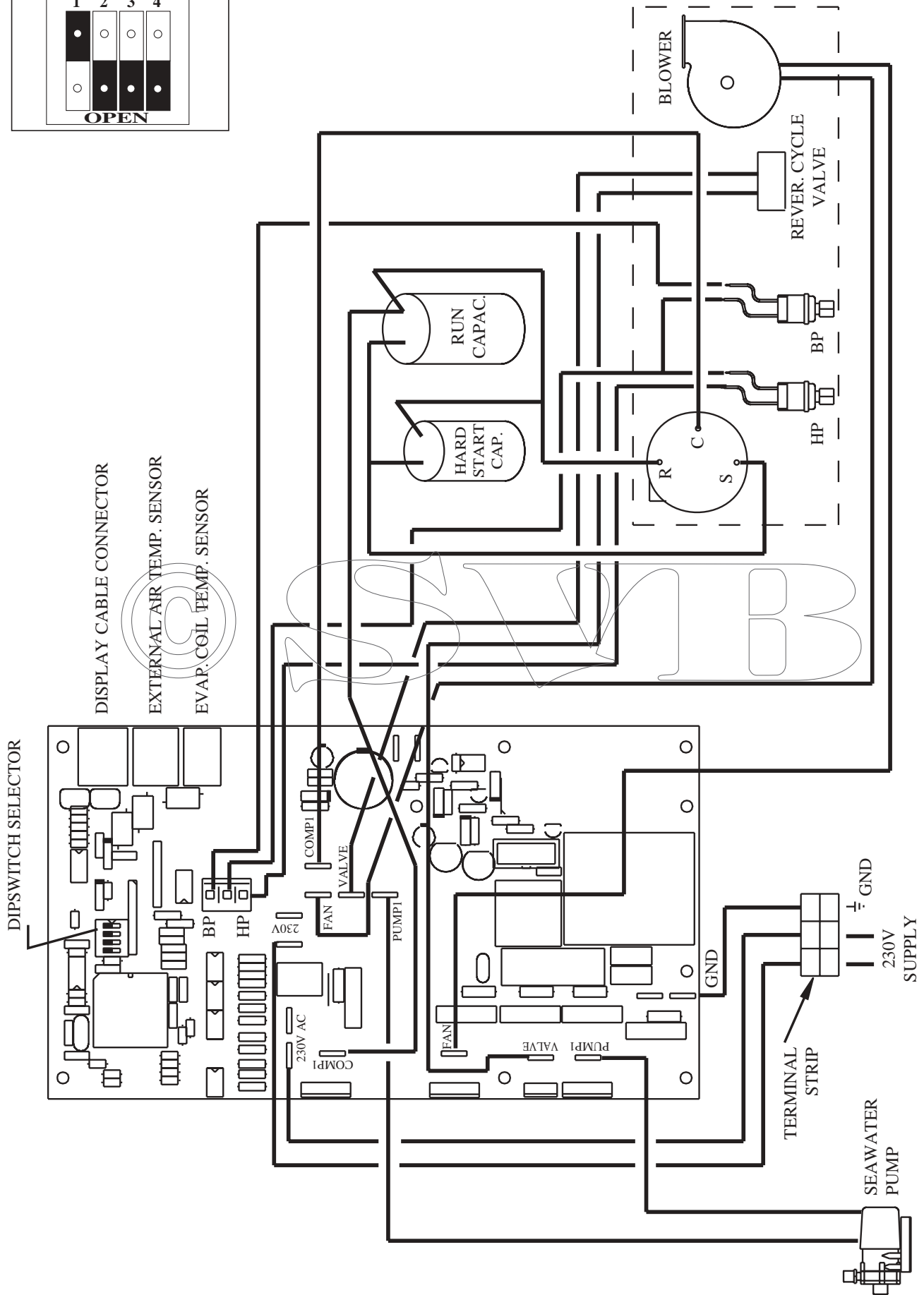
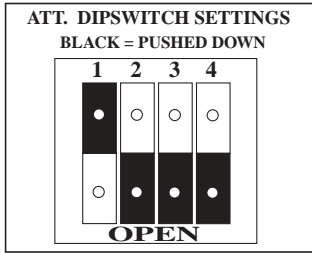

### 10.3 - ELECTRICAL WIRING - WBCC 7 TO 16 - 1 PHASE - PISTON COMPR.

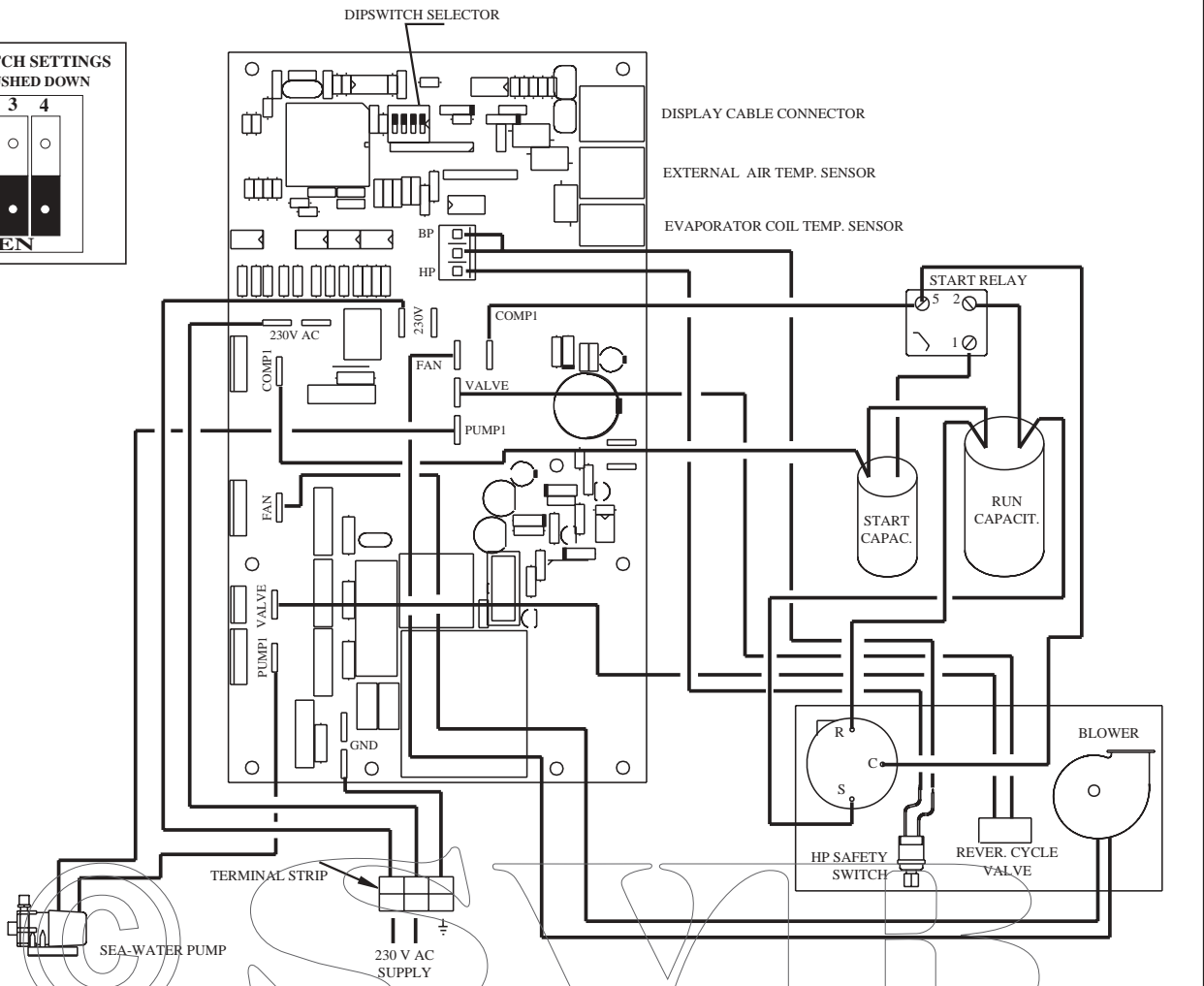
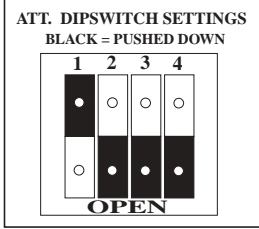

### 10.4 - WIRING SCHEMATICS - RUNNING CAPACITORS FOR BLOWER MOTORS - ECOFIT/EBM

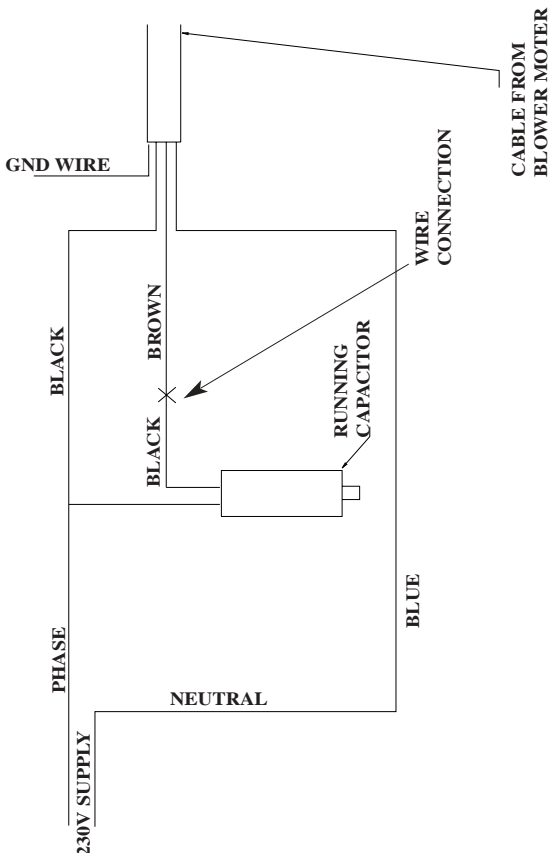

# WEBASTO-REPRESENTATIVES - WEBASTO-VERTRETUNGEN

## Germany - Deutschland

**Bayern, Baden-Württemberg, Hessen** (teilweise), Saarland, Rheinland Pfalz

**Webasto AG**  
Business Unit SPM  
Niederlassung Süd  
Kraillinger Strasse 5, D-82131 Stockdorf  
Tel. +49 89 85794-789, Fax +49 89 85794-702

**Australia- Australien**  
AUS-2229 NSW Caringbah

Webasto Product Australia Pty. Ltd.  
4/65 Captain Cook Drive  
Tel. +61 295 404811, Fax +61 295 404316  
www.webasto.com.au

**Austria - Österreich**  
A-1230 Wien

Webasto Fahrzeugtechnik G.m.b.H.  
Jochen Rindt Strasse 19  
Tel. +43 1 6043780, Fax +43 1 6043786  
www.webasto.at

**Baltic Republics - Baltikum**  
EE-11214 Tallinn

AS KG Knutsson  
Saeveski 12  
Tel. +372 651 9309, Fax +372 651 9303  
www.kgk.ee

**Belarus - Weißrussland**  
BY-220004 Minsk

Falkat GmbH  
8, Per. Obuwnoj  
Tel. +37 50172201894, Fax +37 50172201894

**Belgium - Belgien**  
B-1070 Bruxelles

S.A. Webasto Product Belgium N.V.  
Allée Hof Ter Vleestdreef 1  
Tel. +32 2 5580660, Fax +32 2 5214004  
www.webasto.be

**Bosnia-Herzegovina - Bosnien-Herzegovina**  
SLO-1000 Ljubljana

via Slovenia - Webasto d.o.o. Slovenia

**Bulgaria - Bulgarien**  
BG-1839 Sofia

Rhea MP GmbH  
Boris-Iliev-Strasse 17  
Tel. +359 2 9420-555, Fax +359 2 9420-566  
www.rheagroup.com

**Canada - Kanada**  
USA-48430 Fenton

via USA - Webasto Product North America, I

**China**  
RC-Hong Kong

Webasto Product China Ltd.  
Room 907-910, Yat Chau Int'l. Plaza, 118  
Tel. +852 28 118230, Fax +852 28 563063  
www.webastochina.com

**Croatia - Kroatien**  
SLO-1001 Ljubljana

via Slovenia - Webasto d.o.o. Slovenia

**Czech Republic - Tschechien**  
CZ-140 00 Praha 4

Webasto Thermo s.r.o.  
Na Strži 1373/35  
Tel. +420 2 41045450-7, Fax +420 2 41045458-9  
www.webasto.cz

**Denmark - Dänemark**  
DK-2610 Rødovre

Webasto Product Danmark ApS  
Islevdalvej 182  
Tel. +45 44 522000, Fax +45 44 522019  
www.webasto.dk

**Finland - Finnland**  
FIN-01740 Vantaa

Oy Kaha AB  
Ansatie 2  
Tel. +358 9 61568379, Fax +358 9 61568305  
www.webasto.fi

**France - Frankreich**  
F-91250 Tigery

Webasto Product France S.A.S.  
1, rue de la Haye, Z.A. Paris Sud II  
Tel. +33 1 69138383, Fax +33 1 69130606  
www.webasto.fr

**Greece - Griechenland**  
GR-10442 Athen

Ikaros S.A.  
19, Dimitras Str.  
Tel. +3010 5150235-6, Fax +3010 5151480  
www.ikaros.gr

**Hungary - Ungarn**  
H-1135 Budapest

Webasto-Hungaria Kft.  
Szent Lázló út 73  
Tel. +36 1 3502337, Fax +36 1 3502339  
www.webasto.hu

**Iceland - Island**  
IS-210 Gardabaer

Bilasmidurinn HF.  
Hörgslundi 19  
Tel. +354 5672330, Fax +354 5673844  
www.webasto.com

**India - Indien**  
IND-201301 Noida (U.P.)

Webasto Motherson Sunroofs Ltd.  
A 6, sector 2, Distt. Gautam Budh Nagar  
Tel. +91 120 2551851, Fax +91 120 2521866  
www.motherson.com

**Italy - Italien**  
I-20080 Zibido San Giacomo

Webasto Product Italy S.p.A. (I)  
Via Longarone, 35  
Tel. +39 02 90005011, Fax +39 02 90005189  
www.webasto.it

**Japan**  
J-739-0038 Higashi-Hiroshima-City

Webasto Japan Co., Ltd.  
5-10 Taguchi Research Complex  
Tel. +81 824 253111, Fax +81 824 253152  
www.webasto.co.jp

**Kazakhstan - Kasachstan**  
KZ-480019 Almaty

Kazachstan Truck Service Ltd.  
M-on Atyrau-2, Geb. 111  
Tel. +7 3272 312650, Fax +7 3272 312545

**Hamburg, Bremen Niedersachsen Schleswig Holstein Nordrhein Westfalen Sachsen, Sachsen-Anhalt Mecklenburg-Vorpommern Brandenburg, Berlin Hessen** (teilweise) Thüringen

**Korea (Republic of)**  
ROK680-160 Nam-Gu Ulsan

Webasto DongHee Co., Ltd (WDH)  
579-9 Younyun-Don  
Tel. +82 52 2578190, Fax +82 52 2570171  
www.donghee.co.kr

**Luxembourg - Luxemburg**  
B-1070 Bruxelles

via Belgium - S.A. Webasto Product Belgium N.V.

**Macedonia - Mazedonien**  
SLO-1001 Ljubljana

via Slovenia - Webasto d.o.o. Slovenia

**Mongolia - Mongolei**  
Ulaanbaatar

Mongolia Thermosystems Ltd.  
P.P. Box 49/491  
Tel. +976 11 312 081, Fax +976 11 312 079

**Netherlands - Niederlande**  
NL-8263 BC Kampen

Webasto Product Nederland B.V.  
Constructieweg 47  
Tel. +31 38 3371137, Fax +31 38 3325181  
www.webasto.nl

**New Zealand - Neuseeland**  
AUS-2229 NSW Caringbah

via Australia - Webasto Product Australia Pty. Ltd.

**Norway - Norwegen**  
N-1386 Åsker

Kolberg, Caspary Maskin AS  
Røykenveien 70  
Tel. +47 66 760900, Fax +47 66 760908  
www.webasto.no

**Poland - Polen**  
PL-05-092 Lomianki

Webasto Petemar SP. z.o.o.  
ul. Warszawska 205/219  
Tel. +48 22 7517787, Fax +48 22 7517788  
www.webasto.pl

**Portugal**  
E-08620 Sant Vicenç dels Horts (Barcelona)

via Spain - Webasto Product Ibérica, S.L.

**Romania - Rumänien**  
H-1135 Budapest

via Hungary - Webasto-Hungary Kft.

**Russia - Russland**  
RU-107 065 Moscow

Webasto Rus OOO  
Altayskaya ulitsa 19-1a  
Tel. +7 095 7770245, Fax +7 095 7770246  
www.webasto.ru

**Serbia and Montenegro - Serbien und Montenegro**  
SLO-1000 Ljubljana

via Slovenia - Webasto d.o.o. Slovenia

**Slovakia - Slowakische Republik**  
SK-04012 Košice

Webasto Thermo SK s.r.o.  
Pri Karásnej 1  
Tel. +421 55 6747792, Fax +421 55 6747792  
www.webasto.sk

**Slovenia - Slowenien**  
SLO-1000 Ljubljana

Webasto d.o.o.  
Cesta v. Gorice 34  
Tel. +386 1 2008710, Fax +386 1 2008726  
www.webasto.si

**South Africa - Südafrika**  
ZA-7780 Wetton, Cape Down

Webasto South Africa (Pty) Ltd.  
7 Venus Way Hillstar Industria  
Tel. +27 21 7619971, Fax +27 21 7619980  
www.webasto.co.za

**Spain - Spanien**  
08620 Sant Vicenç dels Horts (Barcelona)

Webasto Product Ibérica, S.L.  
Poligono Industrial La Barruana,  
Avenida de Torrelles 12 y 14  
Tel. +34 93 6724515, Fax +34 93 6724520  
www.webasto.es

**Sweden - Schweden**  
S-19181 Sollentuna/  
Stockholm

KG Knutsson AB  
Hammarbacken 8  
Tel. +46 8 923000, Fax +46 8 923307  
www.webasto.se

**Switzerland - Schweiz**  
CH-4123 Allschwil/BL

Webasto (Schweiz) AG  
Hagmattstrasse 4  
Tel. +41 61 4869580, fax +41 61 4869589  
www.webasto.ch

**Turkey- Türkei**  
TR-34510 Esenyurt - Istanbul

Webasto Termo Sistemleri A.?.  
Evren Oto Sanayi Sitesi  
Tel. +90 212 6721590, Fax +90 212 6721604  
www.webasto.net

**Ukraine**  
UA-290069 Lviv

Webasto Elektron GmbH  
Schewtschenko Str. 315  
Tel. +38 0322 911564, Fax +38 0322 913753  
www.webasto.com

**United Kingdom - Großbritannien**  
GB-DN4 5JH South Yorkshire

Webasto Product UK Ltd.  
Webasto House, White Rose Way,  
Doncaster Carrington  
Tel. +44 1302 322232, Fax +44 1302 322231  
www.webasto.co.uk

**USA**  
USA-48430 Fenton

Webasto Product North America, Inc  
15083 North Road  
Tel. +1 810 593-6000, Fax +1 810 593-6001  
www.webasto.us