

ML-Series
Automatic Charging Relay (ACR)

PN 7620 /PN 7621 (without manual control)

PN 7622 /PN 7623 (with manual control)

- Magnetic Latch (ML)—draws very low current (<10 mA to monitor terminal voltage) in the ON or OFF states, and draws moderate current for very short time when changing state
- Start Isolation (SI)—can be configured for temporary isolation of House loads from Engine circuit during engine cranking to protect sensitive electronics
- Engine Isolation (EI)—can be configured for isolation of two engines while both are running to protect engine electronics and maximize alternator output
- Senses charging on two battery banks
- LED output to remotely indicate when batteries are combined or isolated
- Tin-plated copper studs for maximum conductivity and corrosion resistance
- Label recesses for circuit identification
- Silver alloy contacts provide high reliability for switching live loads

ML-Series ACR Specifications

Cranking Rating: 10 sec.	2,500A DC
Intermittent Rating: 5 min.	See Table Below
Continuous Rating:	See Table Below
Amperage Operating Current:	<40 mA when changing state
Primary Circuit Voltage Rating	32V DC Max.
Relay Contact Position:	
-Combine (30 sec.)	13.5V@12V DC 27.0V@24V DC
-Combine (90 sec.)	13.0V@12V DC 26.0V@24V DC
-Open Low (10 sec.)	12.35V@12V DC 24.7V@24V DC
-Open Low (30 sec.)	12.75V@12V DC 25.5V@24V DC
-Open High	16.2V@12V DC 32.4V@24V DC
Live Current Switching	300A@12V DC—10,000 Cycles
Terminal Stud Size	3/8"-16
Maximum Terminal Stud Torque	140 in-lb (15.5 N•m)
Ring Terminal Size	3/8", M10
Terminal Ring Diameter Clearance	1.18" (28.4mm)
Control Circuit Current Draw	<40 mA

Regulatory Meets ISO 8846 and SAE J1171 external ignition protection requirements, Rated IP66

Remote Control Contura Switch Specifications

Contura Control Switch (included)	Sustained SPDT ON-OFF-ON
Maximum Operating Amperage	20 Amperes@12V DC 15 Amperes@24V DC
Seals	Internal & External Gasket Panel Seal
Operating Temperature Range	-40°C to 85°C
Mounting Hole	1.450"x 0.830" (36.00mm x 21.08mm)
LED Rating	100,000 hours 1/2 life

Regulatory Meets ISO 8846 and SAE J1171 external ignition protection requirements, Rated IP67

Wire Size	Intermittent Rating 5 min.	Continuous Rating
2/0	400 Amps	225 Amps
4/0	400 Amps	300 Amps
2x (4/0)	700 Amps	500 Amps

PN	Termination	Manual Control	Control Circuit
7620	Tinned Wires	No	12V DC
7621	Tinned Wires	No	24V DC

PN	Termination	Manual Control	Control Circuit
7622	Tinned Wires	Yes	12V DC
7623	Tinned Wires	Yes	24V DC

Overview of Application

The ML-Series ACR automatically combines batteries during charging, and isolates batteries when there is no charging sensed on either battery bank.

ML-Series ACR Function	12 Volt DC Operation	24 Volt DC Operation
Automatically combines battery banks when sensed voltage levels are:	Above 13.5V for 30 sec. Above 13.0V for 90 sec.	Above 27.0V for 30 sec. Above 26.0V for 90 sec.
Automatically isolates battery banks when sensed voltage levels are:	Below 9.6V (undervoltage lockout) Below 12.35V for 10 sec. Below 12.75V for 30 sec. Above 16.2V (overvoltage lockout)	Below 19.2V (undervoltage lockout) Below 24.7V for 10 sec. Below 25.5V for 30 sec. Above 32.4V (overvoltage lockout)

Start Isolation or Engine Isolation. The isolation inputs enable one of two functions depending on how the inputs are configured.

NOTE: The ML-Series ACR can be configured for Start Isolation or Engine Isolation, but not both.

- **Start Isolation** - Temporary isolation of house loads from the engine circuit during engine cranking to protect sensitive electronics. Configure Start Isolation when there are heavy cranking loads causing sags and spikes that might damage electronics in the House circuit.
- **Engine Isolation** - Isolate two engines while both are running to protect engine electronics, and to maximize alternator output. Configure Engine Isolation when the engine manufacturer requires it, and when there are separate batteries for each engine.

Undervoltage or Overvoltage Lockout.

- Undervoltage lockout prevents batteries from being combined when either battery is below 9.6V@12V DC operation or 19.2V@24V DC operation.
- Overvoltage lockout prevents batteries from being combined when either battery is above 16.2V@12V DC operation or 32.4V@24V DC operation.

Control Switch Remote Operation. Included Contura Control Switch—sustained (SPDT) ON-OFF-ON. Alternatively use a momentary (SPDT) (ON)-OFF-(ON) or momentary push button switch (sold separately) to provide cross connect and/or battery isolation. The Control Switch should be mounted in a convenient location near helm controls to allow for quick access.

To cross connect (combine) battery banks	Switch to "ON". Combines battery banks to provide more battery power in hard starting situations.
To isolate battery banks	Switch to "OFF". When the battery banks are isolated using the Control Switch, the battery banks remain isolated, and for at least 30 seconds after the control switch is returned to the "AUTO" position.

Remote LED Indicator. A remote LED (sold separately) indicates ACR state or condition as follows:

LED INDICATION	ACR STATE OR CONDITION
Remote Switch Set to AUTO or no Remote Switch Installed	
LED "OFF"	Batteries are isolated
LED "ON"	Batteries are combined
LED steady blinking "ON"-"OFF"	Start or Engine Isolation is causing batteries to be isolated
LED quick blinking "ON"-"OFF"	Undervoltage lockout-- <i>either battery is below 9.6V@12V DC operation or 19.2V@24V DC operation.</i> Overvoltage lockout-- <i>either battery is above 16.2V@12V DC operation or 32.4V@24V DC operation.</i>
Remote Switch Set to OVERRIDE "ON" or "OFF"—Automatic operation is suspended for 10 minutes after remote switch is returned to "AUTO"	
LED double blinking "ON"-"OFF"	Manual override-- <i>check ACR for switch states.</i> OR ACR mechanical failure

Guarantee

Any Blue Sea Systems product with which a customer is not satisfied may be returned for a refund or replacement at any time.

Overview of Application (continued)

To Connect Sustained (SPDT) ON-OFF-ON Contura Control Switch:

1. Connect pin 3 of the Control Switch to DC+ through a 2A (min) circuit protection device.
2. Connect pin 1 to DC ground.
3. Connect pin 2 to ACR "REMOTE" wire (red).
4. Connect pin 8 to DC+ through a 2A (min) circuit protection device.
5. Connect pin 7 to ACR "LED" ground wire (yellow).

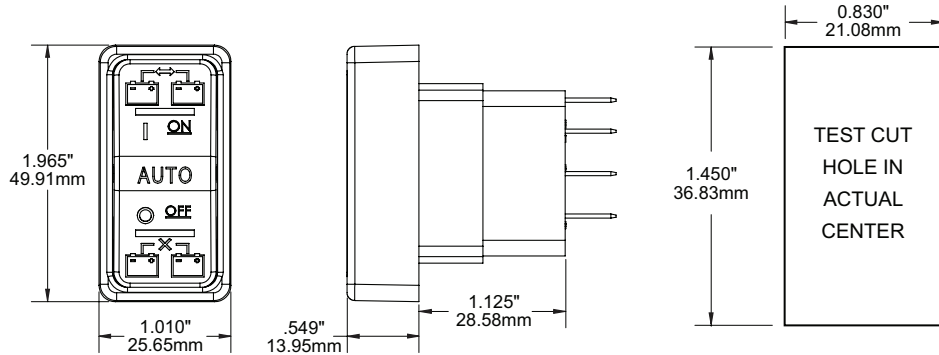

Manual Control Override Knob PN 7622 / PN 7623

The Manual Control Override Knob provides:

- an added level of safety that allows manual ON-OFF control with or without power
- LOCK OFF for servicing the electrical system

Remote LEDs in control switch indicate when ML-Series ACR is in manual override condition.

Manual Control Override Knob Operations* †

To combine battery banks	With Override Knob in (REMOTE position), push button until latched (Push to Latch On).	
To isolate battery banks that are connected	Rotate Override Knob to right to release button from Latch On mode (button pops up). Rotate Override Knob to left (REMOTE position).	
To prevent remote operation	Rotate Override Knob to right (LOCK OFF position).	
To secure for servicing	With Override Knob in (LOCK OFF position), pass cable tie through hole.	

* Operating the Manual Control Override Knob will override automatic operation of the ML-Series ACR for 10 minutes if the override forces a change in switch state.

† The ML-Series ACR will wait 10 minutes if it attempts to automatically close while the manual knob is rotated to LOCK OFF.



- ✓ These instructions are intended to provide assistance with the installation of this product, and are not a substitute for a more comprehensive understanding of electrical systems. We strongly recommend that a competent electrical professional perform the installation of this product.
- ✓ The illustrated wiring diagram represents a common installation and is not meant to be a guide for wiring a specific vessel. The wiring diagram shows a single battery bank installation.
- ✓ Disconnect all negative battery connections before beginning the installation.
- ✓ All unused control wires should be carefully insulated from each other and from accidental contact using heat shrink tubing or electrical tape. External contact or shorting between control wires can lead to malfunction.

Installation Instructions

Mounting

Install the ML-Series ACR as close as possible to both battery banks so that positive and negative wires are as short as possible, and voltage drop in these wires is kept to a minimum‡. To avoid corrosion to terminals and connecting wires, mount in a dry and protected location. Avoid mounting directly above vented lead acid batteries so that the ACR is not exposed to corrosive gasses expelled from the batteries.

‡ Because the ACR senses the voltage between its negative ground connection and its positive sense connections, both positive and negative wires should be as short as possible so that the influence of voltage drop on sensed voltage levels is minimized.

High Current Primary Circuit Connections (stud terminals A and B)

For help selecting the appropriate wire size and circuit protection rating, go to www.blueseas.com and click the *Circuit Wizard* quick link.

NOTES: Stud terminals A and B are interchangeable. Either battery bank can be connected to A or B.

If the ACR is to be used for cross connect, fuses between ACR terminals A and B and each battery positive are not required according to ABYC guidelines. If the ACR is not used for cross connect, install fuses to prevent a hazard if there is damage to the wires connecting the batteries to the ACR. The fuses should be placed as close as possible to the batteries so that most of the wire is protected.

To connect high current circuit wires:

1. Connect the battery banks to the stud terminals marked A and B.
2. Torque the high current terminal stud nuts to 140 in-lbs (15.5 N•m) maximum.

Control Circuit Connection (wire contained in the wire harness)

Ground Connection

Connect the black wire in the wire harness to DC ground at the main ground terminal busbar.

Optional Control Circuit Connections (wires contained in the wire harness)

Cross Connect or Isolate Battery Banks

Use the included Control Switch—sustained (SPDT) ON-OFF-ON.

Alternatively use a momentary (SPDT) (ON)-OFF-(ON) or momentary push button switch (sold separately) to provide cross connect and/or battery isolation. The Control Switch should be mounted in a convenient location near helm controls to allow for quick access.

NOTE: Use 16 AWG wire for all Control Circuit connections. ABYC minimum wire size requirement.

Cross Connect or Isolate Battery Banks Using Optional Control Switch

Use Control Switch – momentary or sustained single pole double throw (SPDT) to provide these settings:

- **CROSS CONNECT (I)** - Battery banks are combined to provide more battery power in hard starting situations.
- **ISOLATE (O)** - Battery banks are isolated until the Control Switch is returned to **AUTO (center position)**. When the Control Switch is returned to **AUTO**, the ACR returns to automatic mode.

To enable cross connect and isolation, connect:

- Red wire from harness to center (common) of SPDT switch.
- **Cross Connect** terminal of SPDT switch to DC positive through 2A circuit protection.
- **Isolate** terminal of SPDT switch to DC negative (ground).

To enable temporary cross connect using momentary push-button switch:

- Connect the red wire from the harness to one side of a momentary push-button switch, (sold separately).
- Connect the other side of the push button switch to DC positive through 2A circuit protection.

Installation Instructions (continued)

To install a remote LED indicator:

- Connect switch pin 8 to DC positive protected by a 2 Amp in-line fuse.
- Connect pin 7 to the yellow wire from the harness.

